

Room Terminal with display HMI Advance

1. Technical data



- Dimensions: 100 x 118 x 31 mm
- Supply voltage: 24 V AC/DC +/- 10%
- TFT LCD color display 240x320px
- Communication link: RS 485
- Compatibility with the drivers from ELP series...
- Networking with multiple PLC Controllers
- Protocol BACnet MS/TP or Modbus
- Built-in temperature sensor
- Storage temperature: -20 – 70 °C
- International Protection Rating (IP): 30

2. Link description

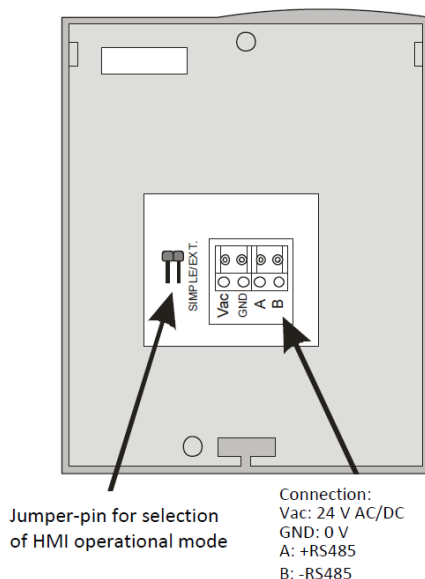

For a full functionality of the HMI, jumper-pin for selection of HMI operational mode must be set up by default. Depending on the PLC application jumper removal, may restrict access to some parameters of the controller to protect them against accidental changes.

3. Wall mounting

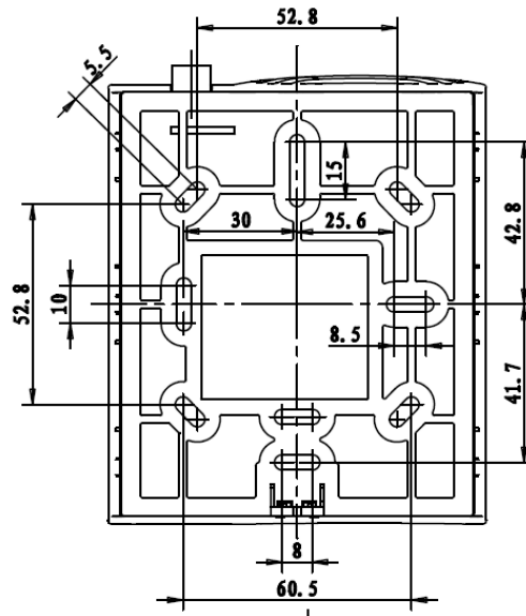

4. Controller connection diagram

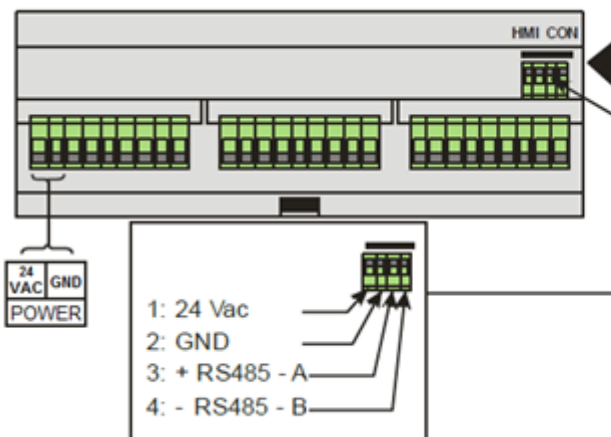

The controllers from ELP series ... have an option to connect HMI to a special connector HMI CON.
(Check availability of this connector in technical details of the selected ELP controller)

In standard configuration each controller comprises:

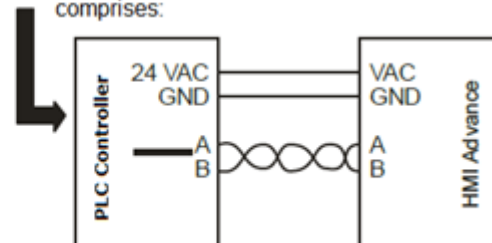

5. Networking scheme with multiple PLC controllers

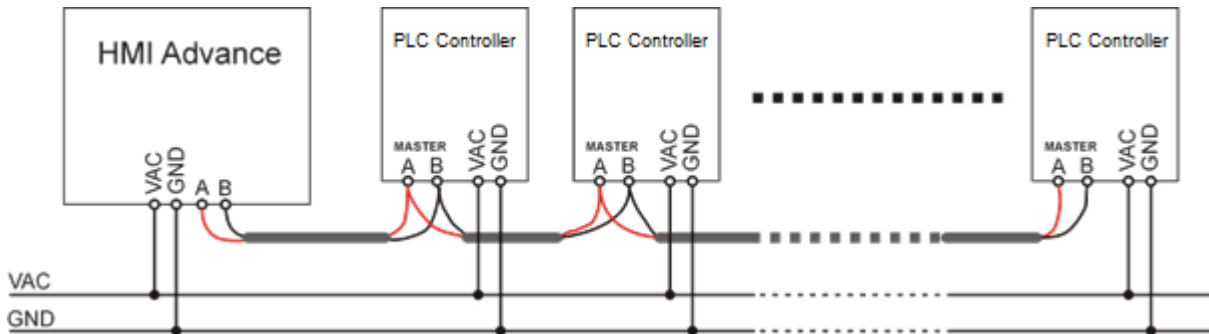

ATTENTION!!!

In Modbus mode, the only possible Master device on the bus is the HMI. This means that the port Master is busy and can not be used for eg. communication with BMS system. In this case, please use other communication ports, change the topology (possible for drivers with Ethernet support, eg. ELP11R32) or use BACnet protocol.

6. Operation

6.1 Definition of keys

▲	<ul style="list-style-type: none"> - Moving to an element located higher in the menu - Parameter value increase using edition mode
▼	<ul style="list-style-type: none"> - Moving to an element located lower in the menu - Parameter value decrease using edition mode
OK	<ul style="list-style-type: none"> - Going deeper in the menu - Start of parameter edition - Confirmation of the new parameter value - (key held for 3 seconds on the list of alarms) alarm confirmation - (key held for 3 seconds on the main screen) passing to the menu
C / 	<ul style="list-style-type: none"> - Exit from menu - Interruption of parameter edition - (key held for 3 seconds) passing to the list alarms

6.2 HMI screens

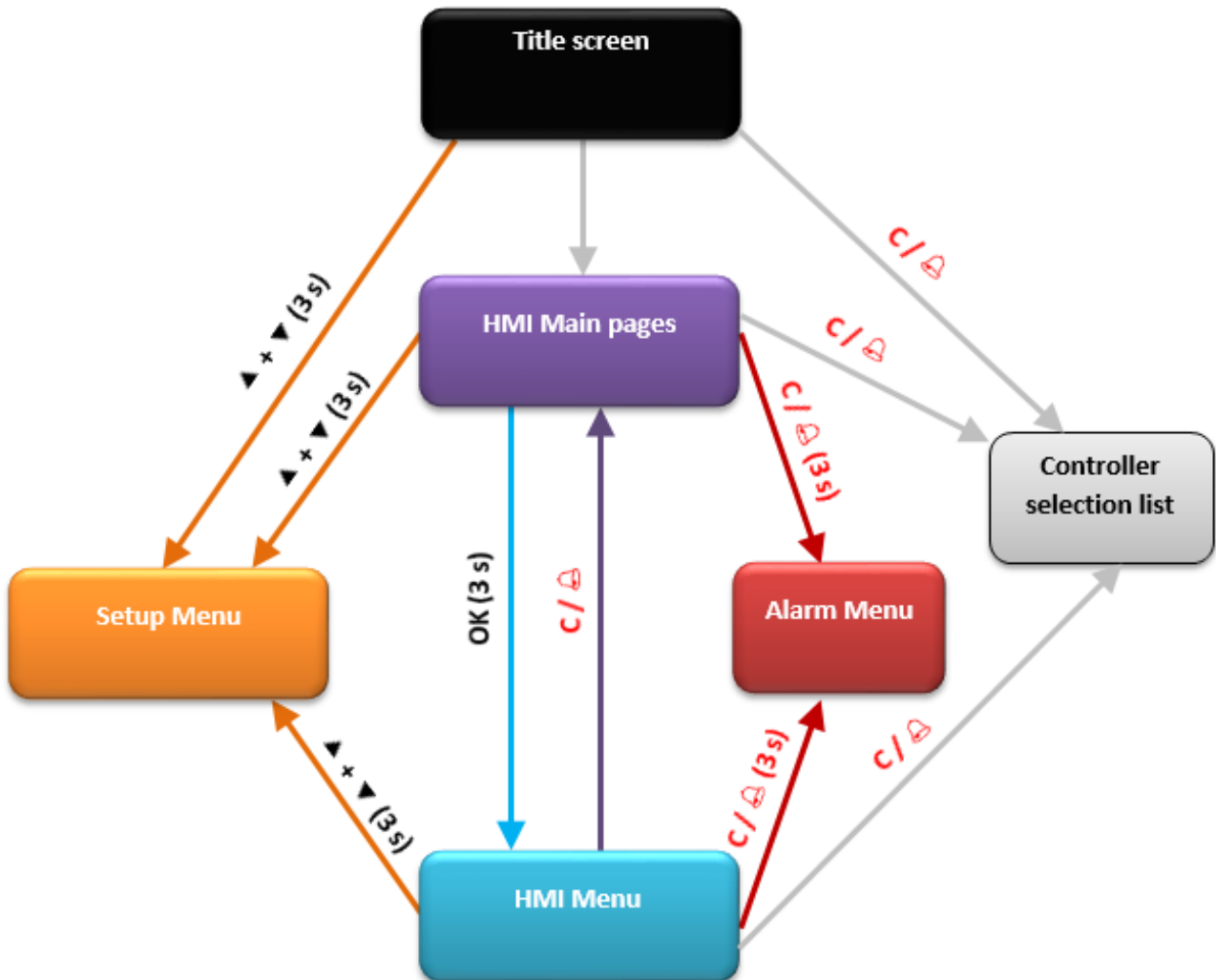

6.3 Main HMI screens

Main HMI screens occur depending on the controller type and its application. These are default screens that appear first after HMI has been switched on. After pressing the **OK** key, a white frame appears around possible to edit parameter (in the first place there is an operating mode). After pressing **▲** or **▼** key the system proceeds to the edition of next available parameter on the screen (e.g. temperature set). Another pressing the **OK** key on the item indicated by a frame makes possible to change the settings using the **▲** or **▼** (which is signaled by a flashing parameter value). The modified parameter value will be approved within 3 seconds or after pressing **OK** key. To cancel modification of parameter value please press **C** key within 3 seconds, before parameter has been automatically confirmed.

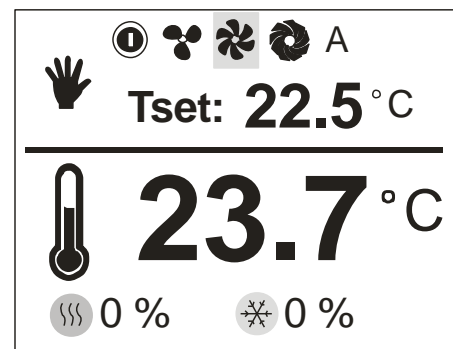

6.4 HMI menu

You can move from the main menu screen to the HMI menu by pressing and holding **OK** key for 3 seconds. If the controller to which HMI is connected does not contain main menu screen, then by default HMI menu is displayed after switching the device on.

HMI menu comprises all parameters that are made available by the controller to the user for viewing and editing. The Menu contains two types of elements: node and parameter. Nodes are access points to the menu levels of detail. Parameters contain values that can be read, but some of them are also modifiable. To access menu level of detail or to proceed to parameter edition please press **OK** key. Pressing of **C** key will cause withdrawal from the menu level or abandoning parameter edition. Alarm is signaled with red background of the HMI menu. To check alarm status the user has to go to the alarm menu.

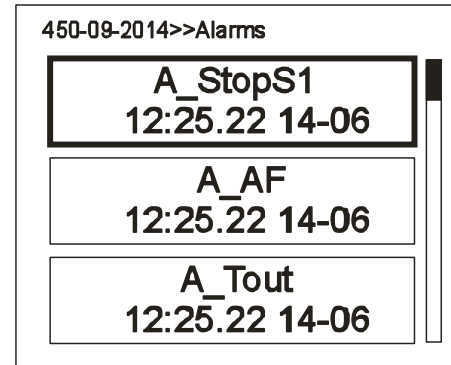

6.5 Alarm menu

You can go from the main menu screen or from HMI menu to the Alarm menu by pressing and holding **C / ⏏** key for 3 seconds. If at a certain point of time alarm is on then its name, date and time of activation will be displayed on the list. Confirmed alarm is additionally marked with asterisk “*”, which is inserted next to the date and time of alarm activation. At the end of the list is a node called “*Alarm History*”. Alarm History displays a chronological list of last occurrences of each alarm.

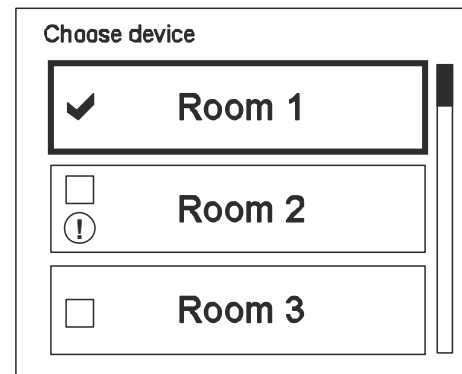

6.6 Controller selection list

In the case of working with multiple PLCs, as defined before in the communication settings, the list of controllers appears when you exit the main menu (key **C / ⏏**) or the main pages (if the controller has a main pages). Select from the list of controller with which you want to set up connection and parameters read out and confirm by pressing **OK** key. On the list of controllers there is also displayed information on the currently read out alarm state of each device. The names of each controllers come from "soft info" of individual applications or name / MAC address of the controller.

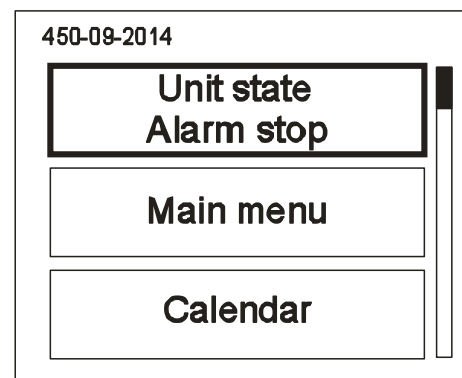

6.7 Setup Menu

Setup Menu is displayed by pressing and holding for 3 seconds ▲ and ▼ keys simultaneously.

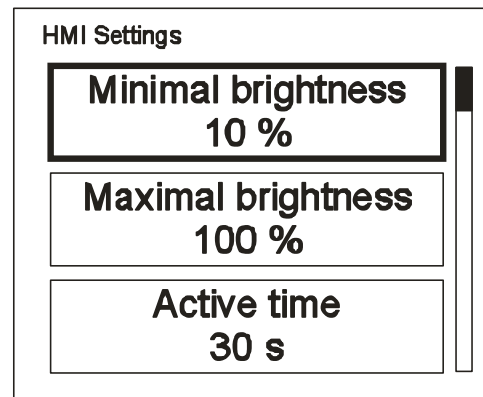

6.8 List of settings:

Minimal brightness	The power of the backlight when the HMI device goes into Ready mode.
Maximal brightness	The power of the backlight when the HMI device is in Active mode.
Active time	Time after which the HMI proceeds to Ready mode when no key has been pressed.
After activ.time	HMI behavior after proceeding into the Ready mode: Nothing – no response (only LCD dimming) Alarm Menu – when alarm has been activated HMI proceeds automatically to the Alarm Menu. Alarm/1st page – when alarm has been activated HMI proceeds automatically to the Alarm Menu, when there is no alarm HMI proceeds to the first page (home page or the first page of Main Menu).
T sensor offset	The offset of temperature measured by the built-in sensor.
Menu skin	An option to select one of the several menu skins.
Menu size	Small – on 1 screen, maximum 3 descriptive fields and 3 variables in the text menus will appear Large – on 1 screen, maximum 6 descriptive fields and 6 variables in the text menus will appear
COMMUNICATION SETTINGS	Options related to HMI communication settings and PLC controllers connected with it. ATTENTION! Changes to settings should be made with care and understanding, because improper use of the guidelines can damage the device, or incorrect operation of the system.

6.9 COMMUNICATION SETTINGS:

<i>HMI COM.SETTINGS</i>	Settings on the HMI only where the activity is carried out.
<i>RS-485 MASTER COM.SETTINGS</i>	Settings on the PLC which is currently established connection with. Enter the menu is not possible if the connection with the controller is not established. Before changing the parameters, make sure that this will not cause loss of communication through improper device identification which change concerns.
<i>MULTI-DEVICE SETTINGS</i>	Settings for HMI working with multiple PLCs. Before changing these parameters, you must configure the connection correctly.
<i>Com.packets lost</i>	The percentage of data packets lost during a communication between HMI and PLC controller. If this number exceeds 30%, check the cables and cable routes between the HMI and the PLC controller.

6.10 HMI COM.SETTINGS:

<i>MAC address</i>	MAC address of the HMI room terminal. Depending on the communication protocol MAC address acts as a Modbus address or MAC address on the BACnet MS/TP.
<i>Instance</i>	The unique device number on a BACnet network
<i>Bus mode</i>	Selection of the communication protocol with a PLC
<i>Com. speed</i>	Setting the serial transmission speed for HMI
<i>Com. parity</i>	Setting the serial transmission parity with a PLC
<i>Com. stop bits</i>	Setting the serial transmission stop bits numbers with PLC

6.11 RS-485 MASTER COM.SETTINGS:

<i>MAC address</i>	MAC address of the PLC controller. Depending on the communication protocol MAC address acts as a Modbus address or MAC address on the BACnet MS/TP. Parameter change is not possible for RS-485 Master port in PLC controllers with built-in address dip switches.
<i>Instance</i>	The unique device number on a BACnet network
<i>Bus mode</i>	Selection of the communication protocol
<i>Com. speed</i>	Setting the serial transmission speed
<i>Com. parity</i>	Setting the serial transmission parity
<i>Com. stop bits</i>	Setting the serial transmission stop bits numbers

6.12 MULTI-DEVICE SETTINGS:

<i>Set only one device HMI CON</i>	When selected, the HMI starts operation with only one PLC controller at MAC address and instance 1. This type of HMI operation is recommended when HMI is connected to a dedicated HMI CON connector on the PLC controller.
<i>Multi-device display</i>	The presentation of the list of the PLC controllers: <i>Dev.name</i> + <i>Soft.ver.</i> - address / instance, the model name, the name of the PLC software <i>Dev.name</i> - address / instance, the model name <i>Soft.ver.</i> - the name of the PLC software
<i>Find devices</i>	Scanning communication network option to create a list of PLC controllers.

When you select scanning communication network option, you must determine the address range / instance to search, and then run the scanner *Scan network*. After the scanning a list of available devices will appear.

Select controllers with which the HMI is to cooperate, and then withdraw from the list by pressing **C** key. When the HMI is configured to work with multiple PLC controllers than all the controllers in the list receive information about the temperature measurement from integrated with HMI temperature sensor. Also, with all the controllers in the list is taken the alarm status. Menu and / or the first pages are displayed only for the currently selected driver from the list.

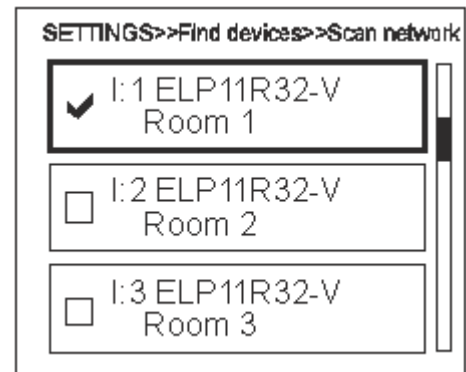

6.13 BACnet object

HMI provides in BACnet network, BACnet object AI-0 under the name DS. This is the current measurement from integrated with HMI temperature sensor.